

SOLAR MODULE 290 W



60 CELLS-POLYCRYSTALLINE



ADVANCED PERC CELL TECHNOLOGY

Absorbing more light, High module efficiency
Low breakage rate, Annual power degradation 0.7%



FAST & SAFE

Easy installation and handling
Environmentally friendly



MODULE DURABILITY

5400 Pa snow load, 2400 Pa wind load
Ideal for PV rooftops, ground mount, floating



THE #1 DOMESTIC PV MANUFACTURER IN VIETNAM

100% Automatic production line
International quality PV technology

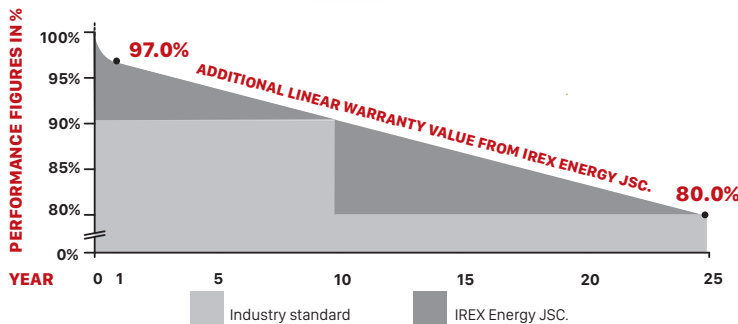

CERTIFICATES



ISO 14001:2015
Environmental
Management
System
qms.com.au

- IEC 61215:** Terrestrial photovoltaic (PV) modules – Design qualification and type approval
- IEC 61730:** Photovoltaic (PV) module safety qualification
- UL 1703, ULC/JORD-C-1703:2018:** Standard for Flat-Plate Photovoltaic Modules and Panels
- IEC 61701:** Salt mist corrosion testing of PV Modules
- IEC 62716:** Photovoltaic modules - Ammonia corrosion testing
- ISO 9001:2015:** Quality Management System
- ISO 14001:2015:** Environmental Management System

HIGH QUALITY FOR PROSPERITY

IREX Energy Joint Stock Company produces the #1 Vietnamese-Made Photovoltaic (PV) modules, internationally certified with excellent performance and flexible in customization per demand.

Going solar requires a long-term commitment. For this, all our solar modules are **insured by MunichRe**, world's best reinsurance provider. You can sit back, relax and enjoy the sunshine; as our company and warranty partner will **always be with you in 25 years!**

With the **finest price and customer service** can only be found at IREX Joint Stock Company, we look forward to working with you soon!

IREX ENERGY JOINT STOCK COMPANY

Head Office: No. 47, Le Van Thinh Street, Quarter 5, Binh Trung Dong Ward, District 2, HCMC, Vietnam
Factory Address: Road No. 1A, Phu My 1 Industrial Zone, Tan Phuoc Ward, Phu My Town, Ba Ria - Vung Tau Province, Vietnam
Tel: +84-28-7300-1559 | **Email:** info@irex.vn | **Website:** www.irex.vn
Fax HCMC: +84-28-7300-6760 | **Fax IREX Factory:** +84-254-2923-594



PERFORMANCE

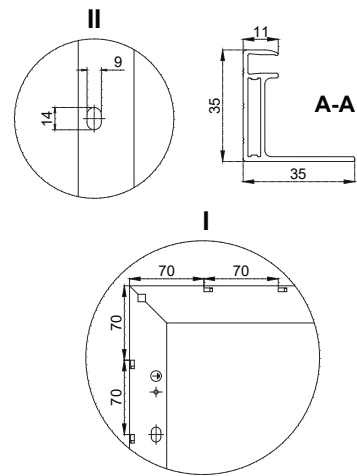
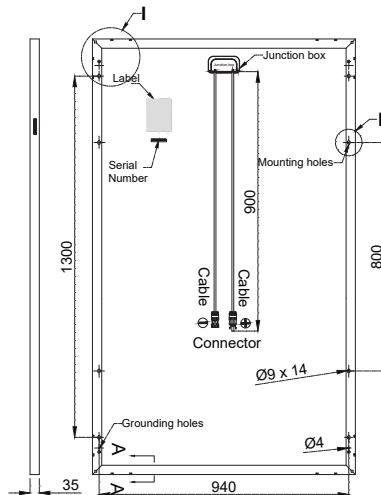
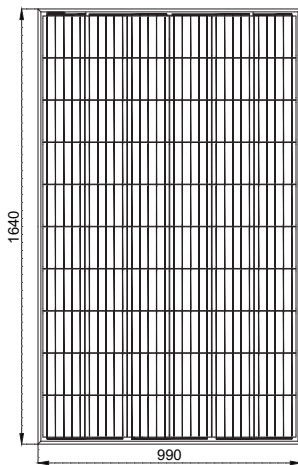
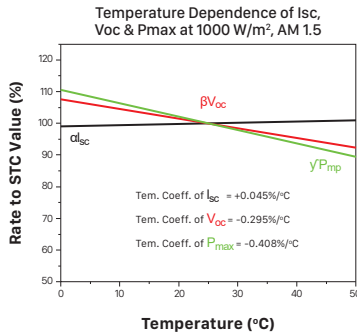
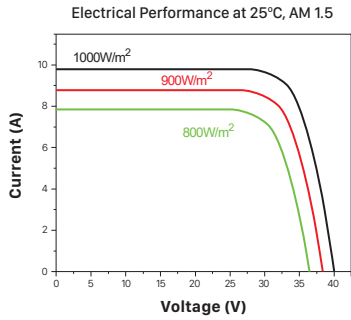

Drawing Only for Reference

ELECTRICAL CHARACTERISTICS STC

IRP60S-290

Maximum Power (P_{max})	290 W
Power Tolerance	0 ~ 3 %
Module Efficiency	17.86 %
Maximum Power Current (I_{mp})	9.09 A
Maximum Power Voltage (V_{mp})	31.91 V
Short Circuit Current (I_{sc})	9.62 A
Open Circuit Voltage (V_{oc})	39.58 V
Module Fire Performance	Type 1 (UL 1703 or Class C (IEC 61730))
Values at Standard Test Conditions	
(STC: AM 1.5 Spectrum, Irradiance of 1000 W/m ² , Cell Temperature 25°C)	

ELECTRICAL CHARACTERISTICS NMOT

IRP60S-285

Maximum Power (P_{max})	212 W
Maximum Power Current (I_{mp})	7.22 A
Maximum Power Voltage (V_{mp})	29.37 V
Short Circuit Current (I_{sc})	7.72 A
Open Circuit Voltage (V_{oc})	36.58 V
Values at Nominal Module Operating Temperature	
(NMOT: AM 1.5 Spectrum, Irradiance of 800 W/m ² , Ambient Temperature 20°C, Wind Speed 1 m/s)	

MECHANICAL CHARACTERISTICS

Cell Type	157 x 157 mm Polycrystalline, 60 (6 x 10) pcs in series
Front Cover	3.2 mm High Transmission, Low Iron, Tempered Glass with Anti-Reflective Coating
Back Cover	Composite film
Frame	Anodized Aluminum Alloy type 6063 - T5 (Silver/ Black)
Junction Box	3 bypass diodes, IP 68 rated in accordance with IEC 62790
Dimension	1640 x 990 x 35 mm
Output Cable	4 mm ² (IEC)/ 12 AWG (UL), 900 mm in accordance with IEC 62852
Weight	19 kg (approx)
Connector	MC4 Compatible

PACKING INFORMATION

Container	20' GP	40' GP	40' HQ
Pallets per Container	12	28	28
Pieces per Container	360	840	896

OPERATING CONDITIONS

Operating Temperature	-40°C ~ +85°C
Maximum System Voltage	1500 VDC (IEC)/ 1500 VDC (UL)
Maximum Series Fuse Rating	20 A (IEC)/ 20 A (UL)
NMOT	45°C ± 2°C
Application Class	Class A