

SOLAR MODULE
380 W

72 CELLS-MONOCRYSTALLINE



ADVANCED PERC CELL TECHNOLOGY

Absorbing more light, High module efficiency
Low breakage rate, Annual power degradation 0.7%



FAST & SAFE

Easy installation and handling
Environmentally friendly



MODULE DURABILITY

5400 Pa snow load, 2400 Pa wind load
Ideal for PV rooftops, ground mount, floating



THE #1 DOMESTIC PV MANUFACTURER IN VIETNAM

100% Automatic production line
International quality PV technology

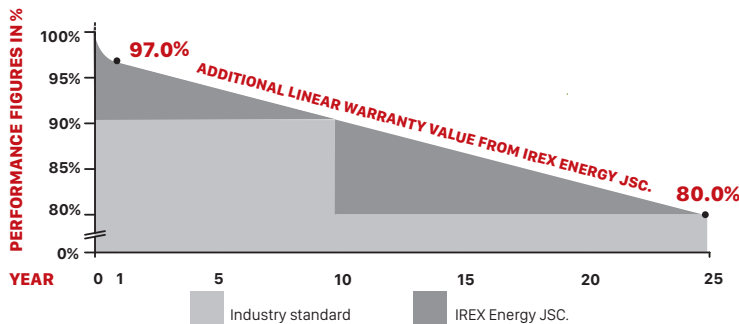

Munich RE

12 - years
Material & workmanship

25 - years
Linear power Output

HIGH QUALITY FOR PROSPERITY

IREX Energy Joint Stock Company produces the #1 Vietnamese-Made Photovoltaic (PV) modules, internationally certified with excellent performance and flexible in customization per demand.

Going solar requires a long-term commitment. For this, all our solar modules are insured by MunichRe, world's best reinsurance provider. You can sit back, relax and enjoy the sunshine; as our company and warranty partner will always be with you in 25 years!

With the finest price and customer service can only be found at IREX Joint Stock Company, we look forward to working with you soon!

CERTIFICATES



ISO 44 100 20 94 0003



ISO 14001:2015
Environmental Management System
certis.com.au
AN 51410994MA

ISO 9001:2015: Quality Management System

ISO 14001:2015: Environmental Management System

IREX ENERGY JOINT STOCK COMPANY

Head Office: No. 47, Le Van Thinh Street, Quarter 5, Binh Trung Dong Ward, District 2, HCMC, Vietnam
Factory Address: Road No. 1A, Phu My 1 Industrial Zone, Tan Phuoc Ward, Phu My Town, Ba Ria - Vung Tau Province, Vietnam
Tel: +84-28-7300-1559 | **Email:** info@irex.vn | **Website:** www.irex.vn
Fax HCMC: +84-28-7300-6760 | **Fax IREX Factory:** +84-254-2923-594



PERFORMANCE

Electrical Performance at 25°C, AM 1.5

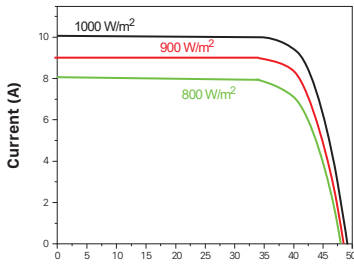

Temperature Dependence of I_{sc} , V_{oc} & P_{max} at 1000 W/m², AM 1.5

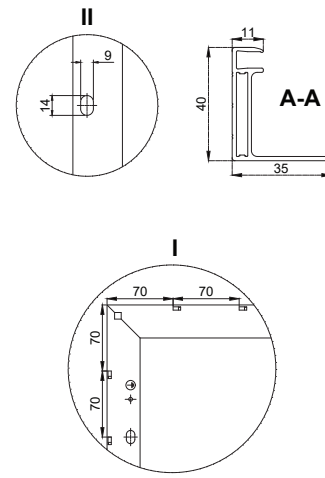
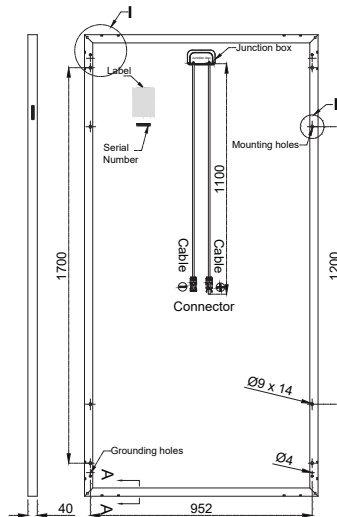
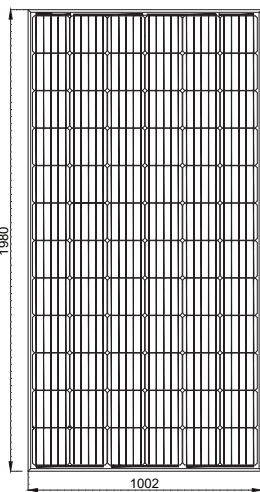
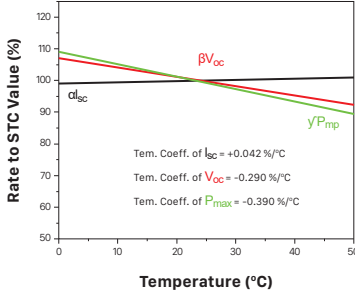

Drawing Only for Reference

ELECTRICAL CHARACTERISTICS STC

IRM72S-380

Maximum Power (P_{max})	380 W
Power Tolerance	0 ~ 3 %
Module Efficiency	19.15 %
Maximum Power Current (I_{mp})	9.31
Maximum Power Voltage (V_{mp})	40.82 A
Short Circuit Current (I_{sc})	9.83 A
Open Circuit Voltage (V_{oc})	48.38 V
Values at Standard Test Conditions (STC: AM 1.5 Spectrum, Irradiance of 1000 W/m², Cell Temperature 25°C)	

ELECTRICAL CHARACTERISTICS NMOT

IRM72S-380

Maximum Power (P_{max})	300.20 W
Maximum Power Current (I_{mp})	7.45 A
Maximum Power Voltage (V_{mp})	40.42 V
Short Circuit Current (I_{sc})	7.87 A
Open Circuit Voltage (V_{oc})	47.90 V
Values at Nominal Module Operating Temperature (NMOT: AM 1.5 Spectrum, Irradiance of 800 W/m², Ambient Temperature 20°C, Wind Speed 1 m/s)	

MECHANICAL CHARACTERISTICS

Cell Type	158.75 x 158.75 mm Monocrystalline, 72 (6 x 12) pcs in series
Front Cover	3.2 mm High Transmission, Low Iron, Tempered Glass with Anti-Reflective Coating
Back Cover	Composite film
Frame	Anodized Aluminum Alloy type 6063 - T5 (Silver/ Black)
Junction Box	3 bypass diodes, IP 68 rated in accordance with IEC 62790
Dimension	1980 x 1002 x 40 mm
Output Cable	4 mm² (IEC)/ 12 AWG (UL), 1100 mm in accordance with IEC 62852
Weight	23 kg (approx)
Connector	MC4 Compatible

PACKING INFORMATION

Container	20' GP	40' GP	40' HQ
Pallets per Container	10	22	22
Pieces per Container	270	594	638

OPERATING CONDITIONS

Operating Temperature	-40°C ~ +85°C
Maximum System Voltage	1500 VDC
Maximum Series Fuse Rating	20 A
NMOT	45°C ± 2°C
Application Class	Class A